

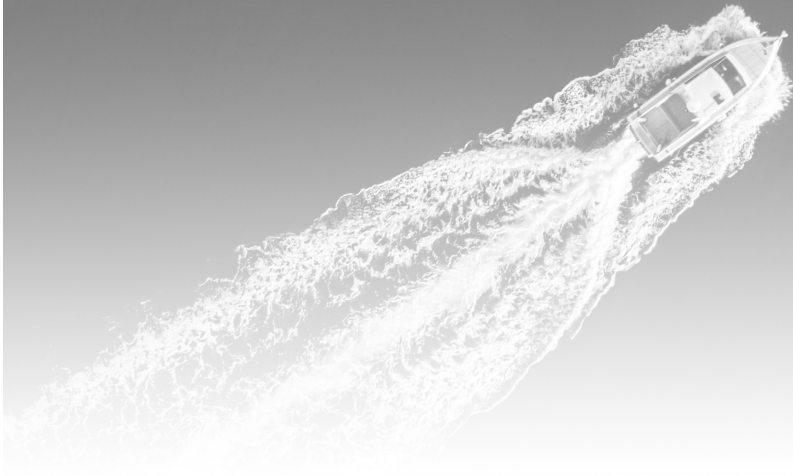

KAPower Starting Module MKSM Models

INSTALLATION – OPERATION MANUAL Gen 3 (12 Volts or 24 Volts)



KBI/Kold-Ban International, Ltd.
8390 Pingree Road, Lake In The Hills, Illinois 60156-9637 U.S.A.
(800) 527-8278, (847) 658-8561, Fax (847) 658-9280, www.koldban.com
ATA VMRS - T44 KLDBN



SAFETY INFORMATION

WARNING and CAUTION symbols are used in this document to alert the reader of possible safety hazards. The reader is responsible for reading and following these alerts.



WARNING indicates a hazardous situation which, if not avoided will result in death or serious injury.



CAUTION indicates a hazardous situation which, if not avoided could result in equipment damage and/or equipment failure.

KBI/Kold-Ban International, Ltd. accepts no responsibility or liability for any of its products that are improperly used. The safety information in this manual is provided as a guide for the user, and is not a substitute for proper training and usage.

NOTE: The information contained in this document is copyright and patent protected. This document may not be copied without express, written permission of KBI/Kold-Ban International, Ltd. Patent information can be found at: http://www.koldban.com/about_KBi_s/1.htm



TABLE OF CONTENTS

1.0	PARTS LIST	4
2.0	ITEMS NEEDED FOR INSTALLATION.....	4
3.0	INTRODUCTION.....	5
3.1	KAPower Advantages	6
3.2	KAPower Basic Description	6
3.3	The KAPower Module	6
3.4	Electrochemical Double-Layer Capacitor (EDLC).....	6
4.0	INSTALLATION.....	6
4.1	Electrical Cable Selection	8
4.2	Mounting the MKSM Unit	9
4.3	General Wiring Installation Procedure.....	13
5.0	OPERATION	29
6.0	TROUBLESHOOTING AND MAINTENANCE.....	30
6.1	To Check MKSM Internal Circuit.....	31
7.0	STORAGE.....	32
8.0	TRANSPORTATION.....	32
9.0	OPTIONAL VOLTMETER HARNESS.....	33
10.0	LIMITED WARRANTY.....	34
	Table 1: Specifications	7
	Table 2: LED Flash Sequence	31
	Figure 1: Parts List Items	4
	Figure 2: Typical Cable Installations	10
	Figure 3: Six (6) Cell KSM.....	11
	Figure 4: Ten (10) and Twelve (12) Cell KSM.....	12
	Figure 5: General Wiring Installation	15
	Figure 6: Standard MKSM Schematic.....	17
	Installation Variation #1: For Boats using a Push button or Key-Switch for Single Engine Starting.....	18
	Installation Variation #2: For Boats using a Push Button or Rocker Switch (DPST) for Engine Starting With Multiple Engines	21
	Installation Variation #3: For Vessels using a Keypad, Digital Switching or Key Switches for Engine Starting with Multiple Engines.	25



1.0 PARTS LIST

1. MKSM Enclosure (See Figure 1)
2. Double Pole Single Throw (DPST) switch (See Figure 1)*
3. Pre-wired harness (Not Shown)
4. Terminal grease (Not Shown)
5. Protective boots (Not Shown)
6. Emergency push button switch (Not Shown) **

* Not included with: MKSMXXX01

** Not Included with: MKSMXXX02

2.0 ITEMS NEEDED FOR INSTALLATION

1. Battery cables (See Section 4.1 for cable recommendations)
2. Terminals for battery cable
3. Torque wrench with $\frac{3}{4}$ inch socket, or $1\frac{1}{16}$ th depending on MKSM model
4. Minimum 16-gauge wire for harnesses



MKSM Enclosure

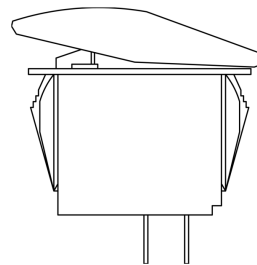

DPST Rocker Switch
(IP 67 Rated)

Figure 1: Parts List Items

NOTE: Not all scenarios and installation methods are covered in this document. If your application does not match any identified in this document, please contact KBI for assistance.



3.0 INTRODUCTION

The MKSM enclosure houses a KAPower module, contactor, PLC Module (Programable Logic Controller), circuit breaker, cables, conductors, and connectors.

KAPower is designed as an auxiliary power source to be installed in parallel with cranking batteries. It derives its power from batteries or an engine charging system and discharges this power when needed. KAPower is intended for supplying electric power to various loads operated in high pulse power (engine cranking) modes. KAPower will enhance and provide for reliable cranking and starting of internal combustion engines. This capability may allow for removal of half or most existing starting batteries.



KAPower is not a high voltage device. It supplies the same amount of voltage as its charge. A charged module should be treated as a fully charged battery.



Do not short circuit KAPower module terminals. Burning or igniting of combustible materials adjacent to the point of short circuit may result from a short circuit. Do not place any conductive objects or materials across terminal posts. In case of accidental short-circuiting of the KAPower module, or individual capacitors, immediately mitigate short by removing the object causing short.



Noncompliance with the requirements set forth in this manual may result in KAPower module failure. Such requirements shall be reviewed and followed during KAPower module operation and installation.



The KAPower module is polarity sensitive. Polarity shall be strictly observed when connecting the KAPower module.



3.1 KAPower Advantages

- Stores Cranking Voltage Until Needed
- Long Service Life – Upwards of a Million Cycles
- Performance Virtually Unaffected by Temperatures
- Increases the Life of Batteries
- Requires NO Maintenance
- Safe and Easy to Install

3.2 KAPower Basic Description

The KAPower module is an energy storage device. KAPower is a high-power device with low energy density. The cranking or discharge periods will be short, but powerful (typically less than 30 seconds), with the time to full recharge rated in tens of seconds. Recharging can be accomplished from virtually any 12-volt or 24-volt DC electrical power source. Cycling, charge, and discharge events will not wear out the device. The Cycle Duty is rated in hundreds of thousands of cycles, approaching one million cycles.

3.3 The KAPower Module

The KAPower module, which is housed within the MKSM enclosure, represents an internal bank of 6, 10, or 12 capacitor cells series-connected to each other.

3.4 Electrochemical Double-Layer Capacitor (EDLC)

An Electrochemical Double-Layer Capacitor represents a device capable of storing and delivering electric power. This is due mainly to the existing capacitance of the double electric layer, which is formed by the capacitor's electrodes being in contact with electrolyte. The capacitor consists of negative and positive electrodes with terminals, separator, electrolyte, and a shell.

4.0 INSTALLATION

Visually inspect the external case prior to mounting the module. Make sure that no traces of physical damage are present on the external case of the KAPower MKSM module.

Before installation, review the KAPower MKSM module specifications. Ensure that the proper device for the specific application is being used. (See Table 1.)



Table 1: Specifications

Specifications				
	12V 6 Cell Unit	12V 10 Cell Unit	24V 10 Cell Unit	24V 12 Cell Unit
Electrical Characteristics				
Operating Voltage Window	6 – 14.5V	6 – 14.5V	12 – 29V	12 – 29V
Maximum Voltage	18V	18V	30V	33V
Minimum Voltage	0V	0V	0V	0V
Internal Resistance	0.0011 ohms	0.0008 ohms	0.0019 ohms	0.0022 ohms
Capacitance	525 F	1250 F	315 F	263 F
Energy Stored within Operating Voltage Window	42.3 kJ	101.6 kJ	122.4 kJ	102 kJ
Energy Stored at Max Voltage	85.1 kJ	141.8 kJ	141.8 kJ	142.9 kJ
Maximum Power	47 kW	112 kW	112 kW	94 kW
Leakage Current at Max Voltage	4.5 mA	4.5 mA	4.5 mA	4.5 mA
Operating Conditions				
Operating Temperature Range	-40° – 149°F (-40° – 65°C)	-40° – 149°F (-40° – 65°C)	-40° – 149°F (-40° – 65°C)	-40° – 149°F (-40° – 65°C)
Cycle Life	>1,000,000	>1,000,000	>1,000,000	>1,000,000
Dimensions and Weight				
Length x Width x Height (IN)	14.79" x 7.75" x 8"	19.44" x 7.75" x 8"	19.44" x 7.75" x 8"	19.44" x 7.75" x 8"
Length x Width x Height (MM)	375.7 x 196.8 x 203.2	493.8 x 196.8 x 203.2	493.8 x 196.8 x 203.2	493.8 x 196.8 x 203.2
Weight	22 lb. (10Kg)	32.5 lb. (14.75Kg)	32.5 lb. (14.75Kg)	34.5 lb. (15.6Kg)

Module Application and Part Number Reference Guide:

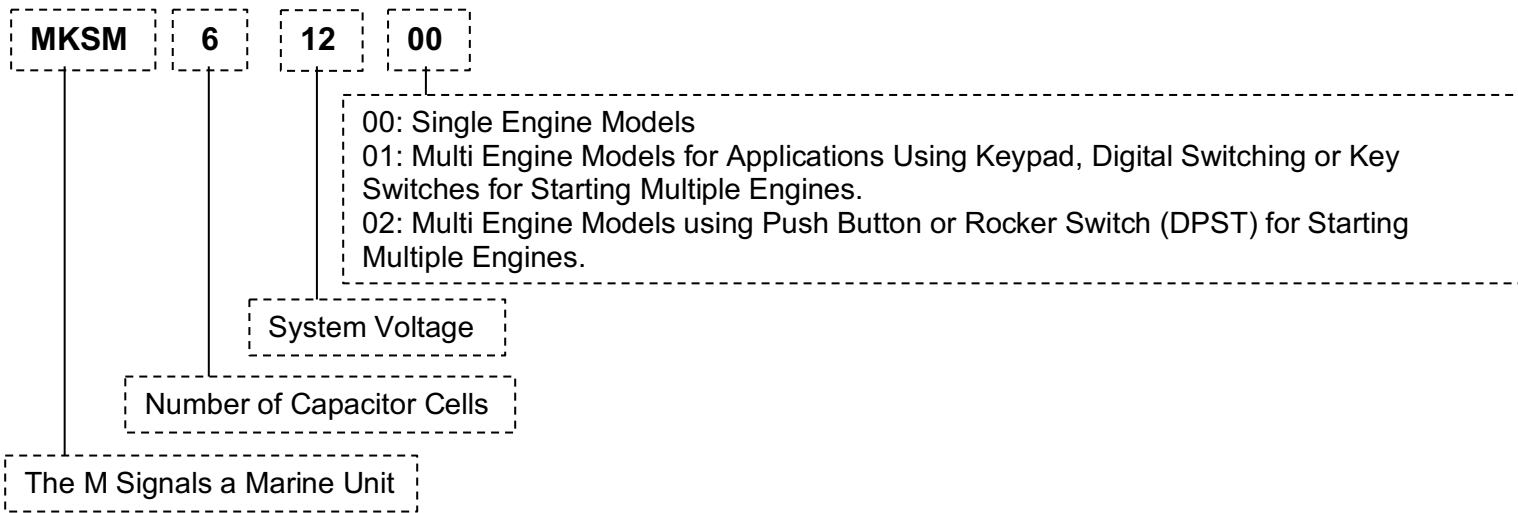



CAUTION

Electrical resistance in a circuit is the consumer of the electrical energy. When installing a KAPower Module, keep resistance to a minimum. Short, heavy cables, and clean cable connections are essential to reducing the amount of resistance in a circuit.

CAUTION

When selecting a location for installation, make sure that the KAPower MKSM module will clear any lids and other movable parts. Install the KAPower MKSM module as close to the engine's starting batteries or starter as possible. Avoid locations that are subject to extreme heat, humidity, dripping water (under deck ventilation systems aboard boats, for example), road dirt, ice, and snow. Prevent the external case of the KAPower MKSM module from physical impacts.

4.1 Electrical Cable Selection

1. Electrical resistance in a circuit is a significant consumer of the power available in the KAPower device. Create and keep the integrity of the circuit to the highest possible standards. Use high strand count cable that is abrasion resistant.
2. Use the heaviest gauge cable available. For 24-volt (and 10 cell units), use at least 2/0, with 4/0 being recommended. A six cell, 12-volt unit may use 4 gauge to 2/0 cables.
3. Keep cable length to an absolute minimum. The circuit resistance increases with cable length.
4. Ensure that the cable termination connections (terminals) are properly crimped and ensure that the holes in ring terminals match the size of the studs over which they are placed. Marine applications should utilize tinned cable and dielectric grease.
5. The quality of the cable connections from the MKSM to the vehicle's or vessel's battery/starter circuit, or equipment, is critical. Make sure to provide good, clean, robust cable interface connections. The cables between the MKSM module and the battery are cranking motor conductors, and therefore are typically not equipped with a fuse or circuit breaker. If a short circuit occurs, the cable will overheat, and it may catch fire, or ignite nearby combustible materials. Therefore, make certain the cable is well-secured, at least every 18-inches, and protected from damage and chafe. For marine installations, follow American Boat and Yacht Council Guidelines found in chapter E-11 (not included in this document).



6. The 4 Pin Deutsch connector has been supplied with a mating connector. Be sure to follow proper wire schemes as identified in the diagrams.
7. The supplied DPST switch may be installed in addition to or paralleling the existing key-start switch. Locate and install the DPST switch in a convenient location relative to the key switch.

4.2 Mounting the MKSM Unit

Using the dimensions shown in Figures 3, and 4, use four (4) ¼” bolts, nuts, and lock washers (not supplied) to mount the MKSM unit to vehicle, vessel, or equipment chassis. If mounting on a solid bulkhead or other location without backside access, other fasteners such as suitably-sized self tapping screws can be used.

CAUTION

When selecting a location for installation, make sure that the MKSM module and cables will clear any hoods, hatches, lids, covers, and other movable vehicle, vessel or equipment parts. Avoid locations that are subject to extreme heat, dripping water, humidity, road dirt, ice, and snow. While the MKSM unit may be mounted in any position or orientation, do not mount it directly over batteries, or under ventilation systems through which water might drip. The internal components of the MKSM are IP67 rated, but the MKSM itself is not IP rated. Take care to prevent the external case of the MKSM module from receiving any physical impacts.



Notes:
4/0 Cable Recommended
2/0 For 6-Cell KSM
Any Battery Selector Switch Can Remain In Place

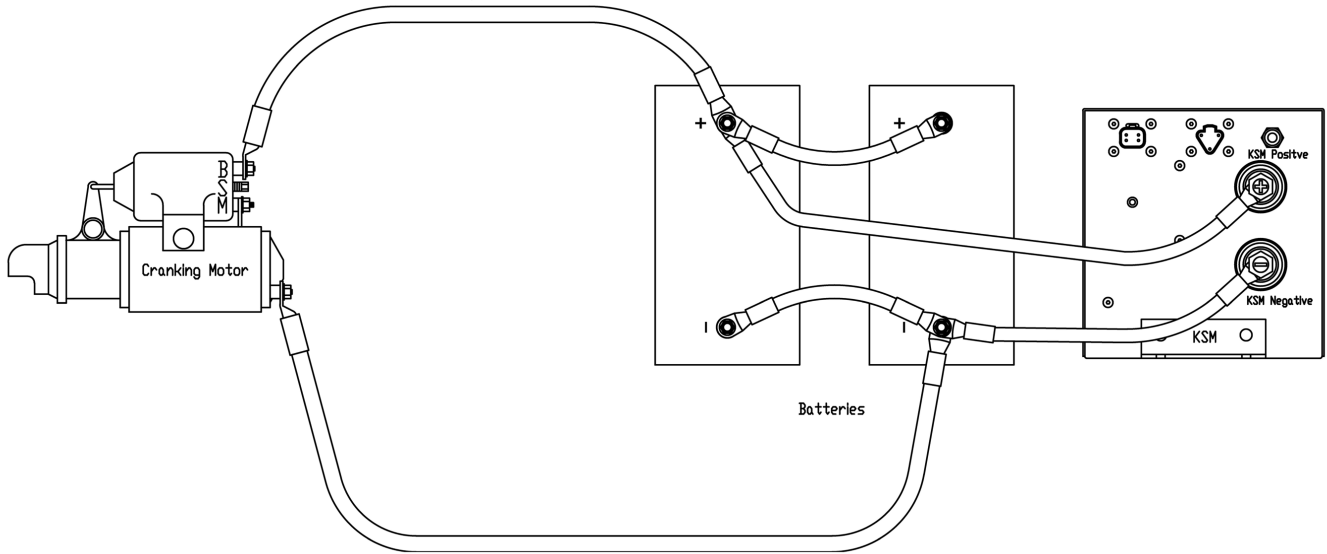

4/0 Cable Recommended
2/0 For 6-Cell KSM

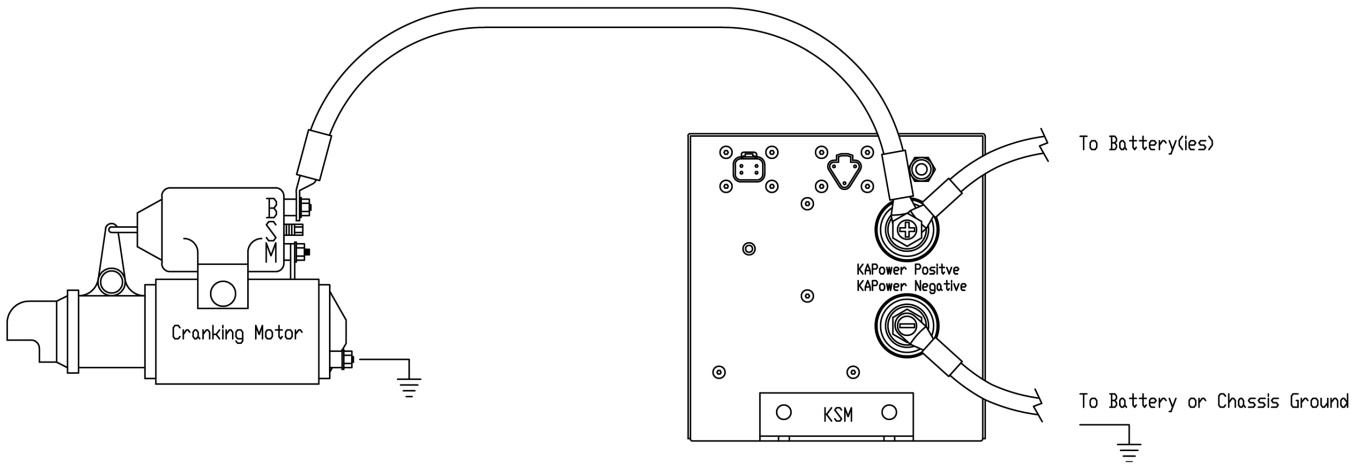

Figure 2: Typical Cable Installations



Material:
Shell: 16ga SS 304 2B
Cover: 18ga SS 304 2B

Weight: 21.5lb (9.75Kg)

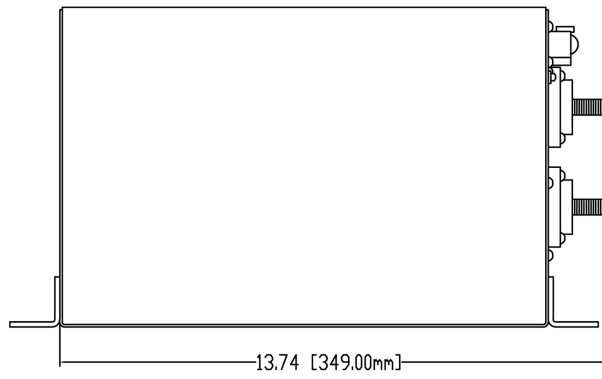
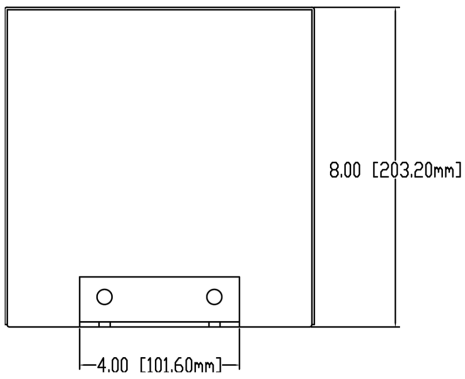
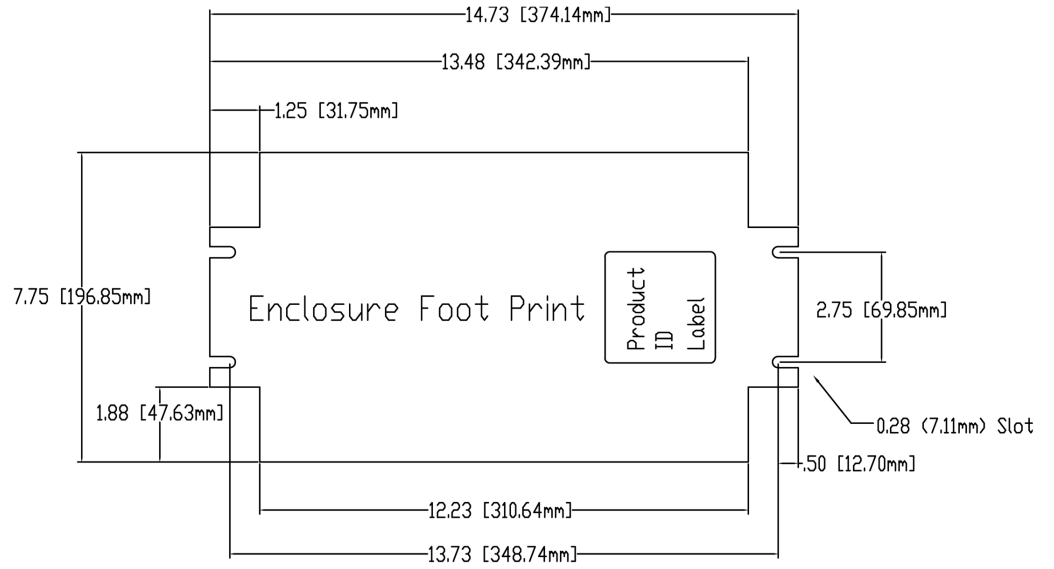

Figure 3: Six (6) Cell MKSM



Material:

Shell: 16ga SS 304 2B

Cover: 18ga SS 304 2B

Weight: 32.5lb (14.75kg)

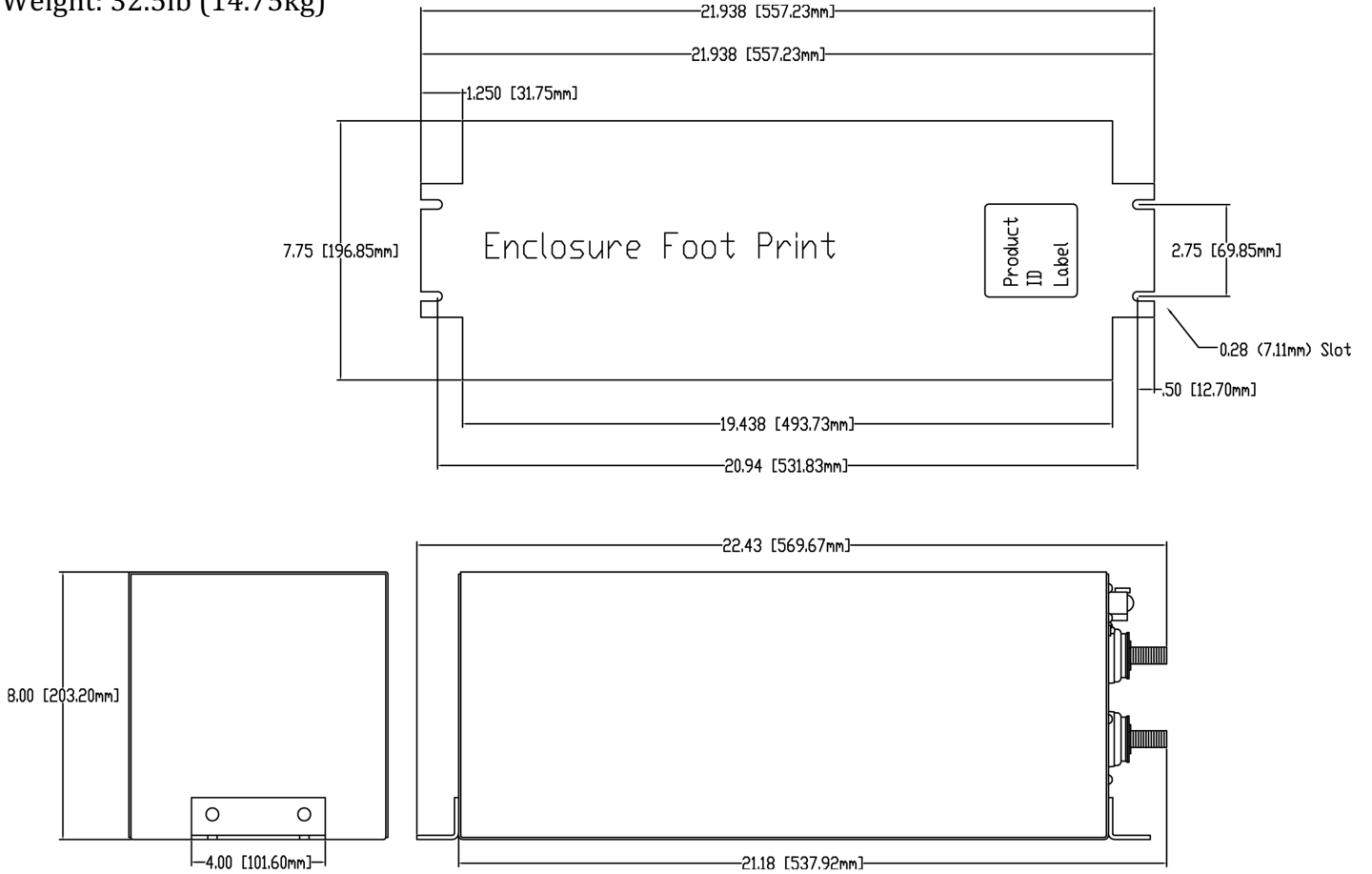

Figure 4: Ten (10) and Twelve (12) Cell MKSM



4.3 General Wiring Installation Procedure

The following is the standard MKSM installation method. However, many vessels will use a variation of this method. After reading the Theory of Operation below, see the following sections if any of these apply to your vessel:

Installation Variation #1 found on page 18. For vessels using a push button, or key-switch for single engine starting.

Installation Variation #2 found on page 21. For vessels using push button or rocker switch (KBI supplied DPST) starting with multiple engines.

Installation Variation #3 found on page 25. For vessels using a keypad, digital switching or key switches for multiple engine starting. Also used for boats with multiple engines not using the DPST installation method.

NOTE: Not all scenarios and installation methods are covered in this document. If your application does not match any identified in this document, please contact KBI for assistance.

Theory of Operation, Explaining how the MKSM Module Works:

Once installed and wired properly, the LED on the end-faceplate of the MKSM will be illuminated green whenever the MKSM contactor relay is closed. When the LED is illuminated, the contactor is closed; the KAPower Module is running parallel with the vehicle, vessel, or equipment batteries and electrical system.

Pressing the DPST switch closes the contactor inside the MKSM enclosure, using power from the KAPower module, regardless of the state of charge of the vessel or equipment's batteries. Pressing the DPST switch also engages the cranking motor circuit, just as if the key switch to the crank/start position had been turned, or the vehicle's or vessel's start button (if so equipped) had been pressed. As such the DPST switch is wired in parallel with the existing starting system. This is done by wiring and using the recommended electrical circuit, displayed on the schematics in Figure 5 (page 15), and Figure 6 (page 17). This creates a parallel circuit with the OEM (Original Equipment Manufacturer) electrical circuit, allowing both the MKSM and the OEM cranking motor circuit to be engaged, simultaneously. Once the engine starts, the Programmable Logic Controller (PLC) inside the MKSM monitors the condition of the KAPower Module, and will close or open the contactor relay inside the MKSM, based on the preprogrammed parameters inside the PLC. When the engine is stopped, the equipment is turned off, the contactor opens and the KAPower module remains isolated, waiting for the next engine-starting event, when the DPST switch is pressed.



The PLC Pre-programmed Functions:

The PLC has been preprogrammed to monitor and control the state-of-charge of the KAPower capacitor module based on temperature, voltage, and time. Once a voltage signal is received at pin four (4) of the Wiring Interface Connector, the PLC “wakes-up” and will determine when and how long to keep the contactor closed. Anytime the LED Status Indicator is illuminated, the contactor is closed. In a typical engine-starting event, the LED will illuminate during engine cranking, and then go out for several seconds after the engine has started. The LED will then illuminate again and could remain illuminated for several seconds based on the condition of the KAPower module. The LED may even begin to “cycle” depending on the vehicle/vessel, or system voltage during the recharging events.

The J1939 connector is used for KBI factory programming only. Contact KBI for details.



Wiring Interface
Connector,
Mating Connector
DT04-4P

J1939 Connector

5 Amp Circuit
Breaker

Power Studs: $\frac{3}{8}$ Inch
Torque: 212 Inch Lbs (23.95 N.m)
Power Studs: $\frac{1}{2}$ -13
Torque: 180 Inch Pounds (20.33 N.m)
Nuts, Lock Washers, and
Isolation Boots Included

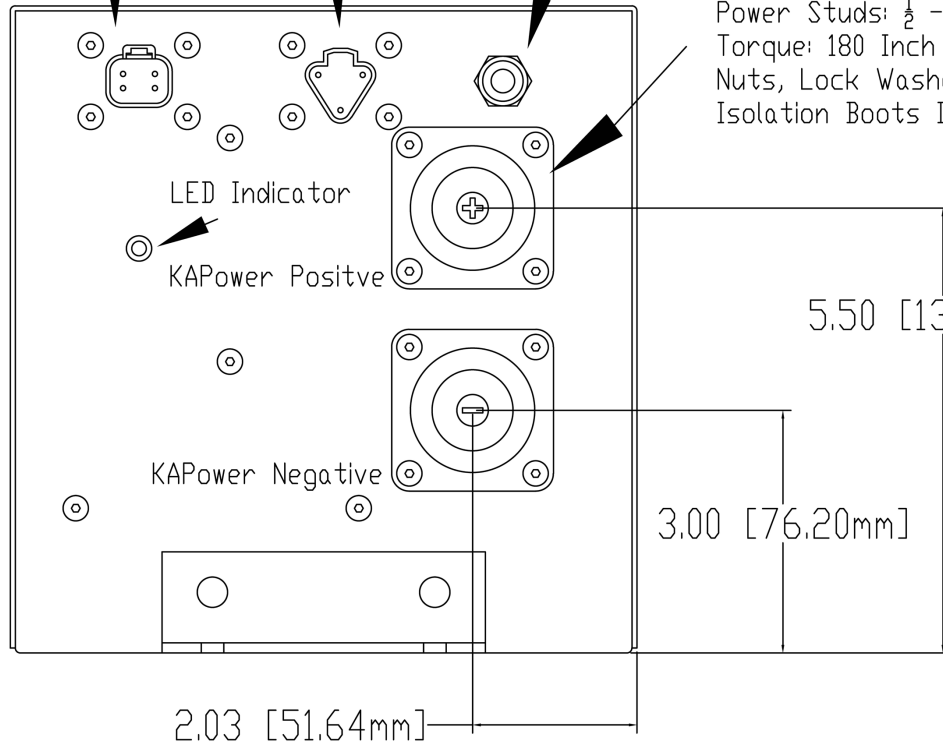

Wire Interface Connector Pin-Out

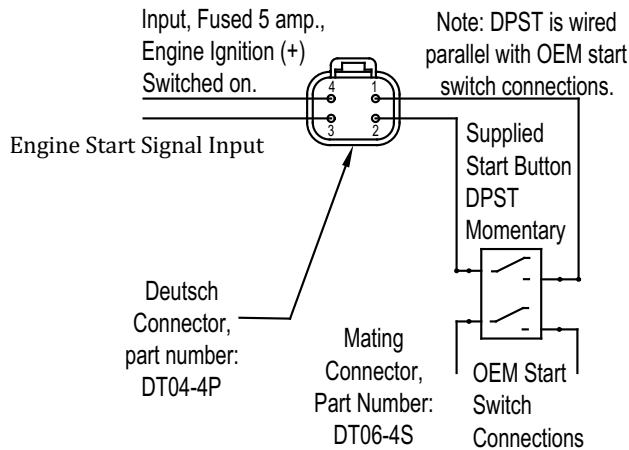

J1939 Connector Pin-Out

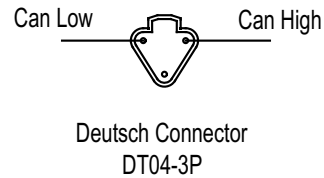

The J1939 connector is used for KBI factory programming only. Contact KBI for details.

CONNECTORS LOCATED ON THE END-FACEPLATE OF THE MKSM ENCLOSURE

Figure 5: General Wiring Installation



4.4 Wiring Installation Procedure

1. Before attaching the large battery cables to the MKSM posts, slide included protective boots onto the cables. The first cable shall be connected to the positive (+) terminal of the MKSM, and then connected to the positive (+) terminal of the battery, or starter.
2. Slide included protective boot onto the negative (-) cable. This second cable shall be connected to the negative (-) clamp, or terminal of the battery, engine, or chassis ground and then connected to the negative (-) terminal of the MKSM module.
3. As based on Figure 5, and Figure 6 create and wire the harnesses to the Deutsch connector. The MKSM Deutsch connector has been provided with a mating connector that has pigtail wire leads tagged and identified in order to facilitate installation.
4. For the PLC input, pin four (4) of the wire interface connector, find a 5-amp power source from the vehicle, or vessel “key-on” ignition source that is live positive (+) **only**, when the ignition switch is on, and is capable of delivering up to 5 amps. This can often be sourced at the engine. Install a 5-amp fuse in this circuit within 7-inches of the power source. Use care not to disturb or compromise the engine’s own wiring harness, or connections.

NOTE: The PLC inside the MKSM needs power (approximately 2.5 amps) from a source, such as a key switch, that provides power only when the vehicle or boat is in operation. Consider this additional 2.5 amps of power and how it may influence the source. This new circuit should be protected with a 5-amp fuse or circuit breaker per ABYC standards in marine applications.

5. Wire the DPST switch by replacing the existing vehicle, vessel, or equipment push button engine starting switch with the KBI supplied DPST switch. Then find and wire the appropriate PLC input (pin 4) as based and depicted on Figure 5, and Figure 6. Do not connect any wiring to the J1939 Connector. *The J1939 CAN-Bus is used for KBI Factory programming only. Contact KBI for details.*
6. Apply provided protective grease on MKSM positive (+) and negative (-) terminals.
7. Attach provided protective boots to terminals on MKSM module.
8. To monitor the MKSM state of charge, order and install the KBI Voltmeter wire-harness, and connector accessory kit, KBI part number 302809. See page 33. The meter used may be digital, or analogue; however, it **must** be activated only with a momentary ON switch or button. Permanently wiring a voltmeter to the MKSM will accelerate the depletion of its charge.
9. Wiring is complete and the unit is now ready to operate.



After the installation and wiring are complete, and whenever the DPST switch is pressed, the MKSM positive (+) and negative (-) terminals will be live. Do not short-circuit the terminals.

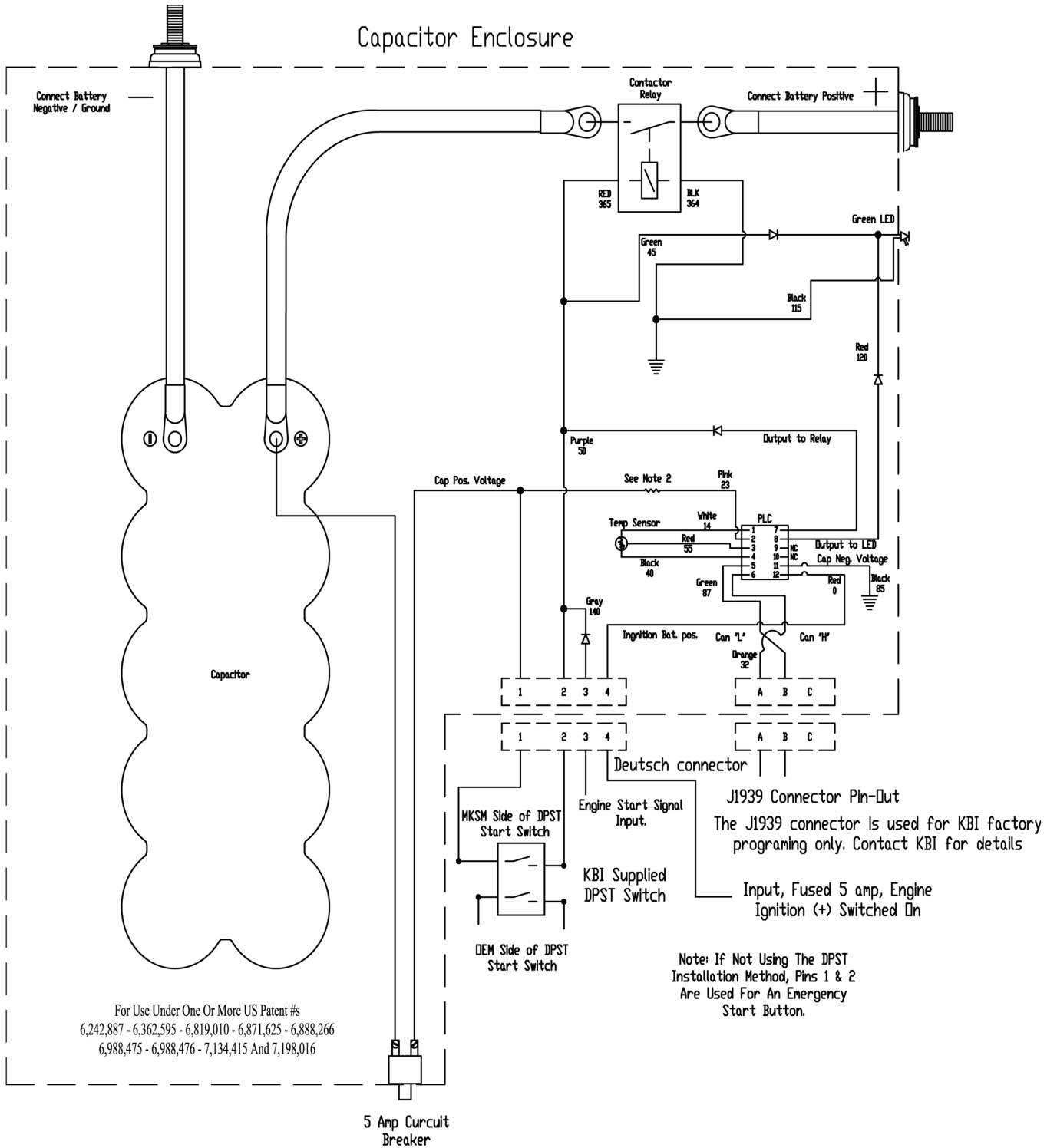

**Figure 6: Standard MKSM Schematic
(MKSMXXX00 Models)**



Installation Variation #1: Supplement for boats using a key-switch for single engine starting.

For use with MKSMXXX00 Models

NOTE: The PLC inside the MKSM needs power (approximately 2.5 amps) from a source, such as a key switch, that provides power only when the boat is in operation. Consider this additional 2.5 amps of power and how it may affect the reliability of the source. This new circuit should be protected with a 5-amp fuse or circuit breaker per ABYC standards, and it should in no way affect the integrity of the engine’s starting or running operation.

NOTE: The following install variation is an **alternate method** for installations on vessels with key-switch starting.

When installing MKSM on a boat that incorporates key switch starting, no rocker switch or push button replacement switch is required.

NOTE: If the OEM engine manufacturer or the boat builder reviews the KBI MKSM Theory of Operation (page 13 + 14) and the requirements for DPST-type functionality, then incorporating the DPST-type function and engineering it into the factory build key-switch should be no problem. However, when installing a MKSM on a boat that has already been built with key-switch starting, the following procedure and hardware (wiring) should be used.

NOTE: If battery power was insufficient (<7 volts), too weak to enable an engine start or provide adequate power to the “S” terminal, an emergency start button should be installed (installed near the controls) and would supply capacitor power to enable the entire MKSM system when the button is pushed.

Figure A1: Typical Boat Key-Switch Schematic.....19

Figure A2: Schematic, Alternate Source for Start Signal..... 20



The PLC inside the MKSM needs power at pin four from a source, such as the key-switch, that provides power only when the boat is in operation. See Figure A1.



Example of existing key-switch.

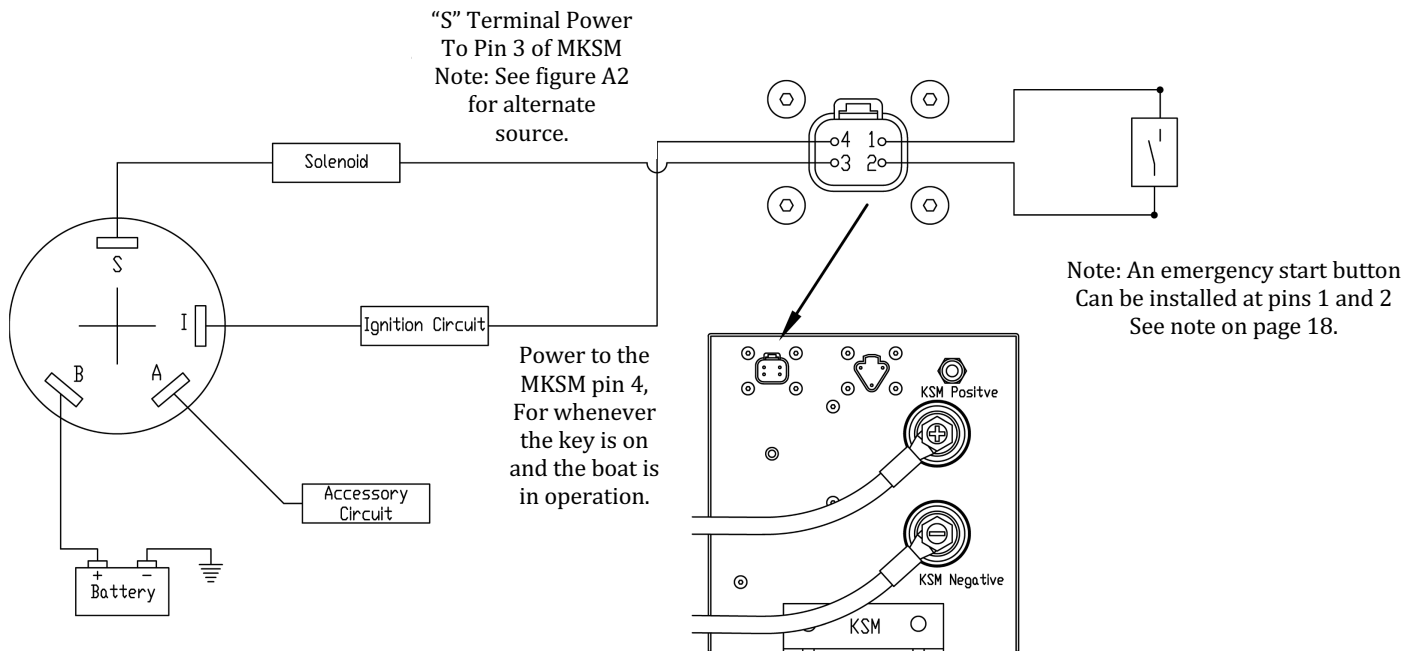
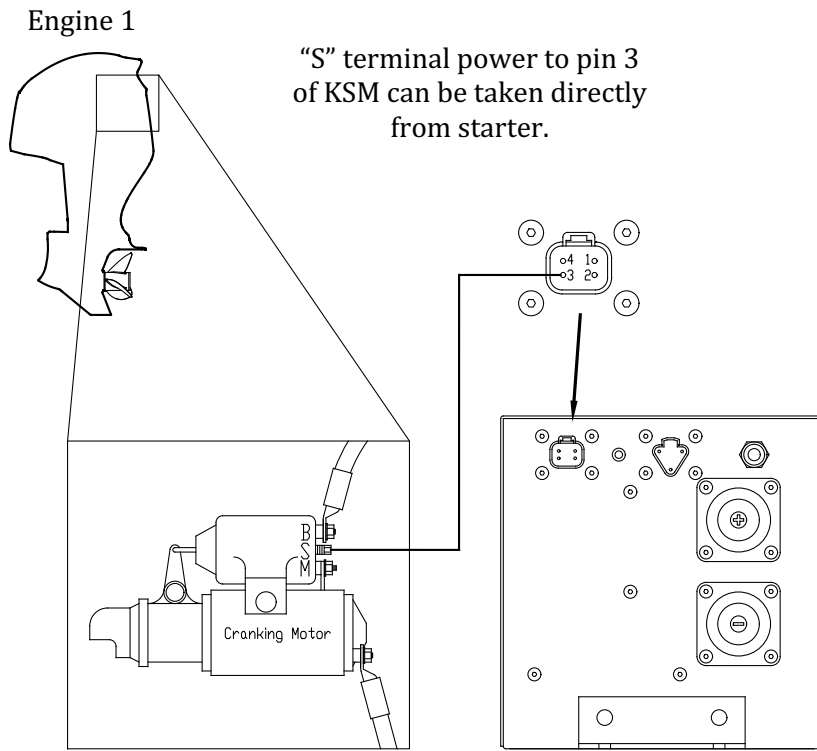

Figure A1: Typical Boat Key-Switch Schematic
For use with MKSMXXX00 Models



NOTE: “S” terminal receives power when the key-switch initiates an engine starting event. The power is also supplied to Pin 3 of the MKSM, bringing the MKSM online to supply engine starting power.



**Figure A2: Schematic, Alternate Source for Start Signal
For use with MKSMXXX00 Models**



Installation Variation #2: Supplement for boats using a push button or rocker Switch for engine Starting with multiple Engines.

For use with MKSMXXX02 Models

NOTE: The PLC inside the MKSM needs power (approximately 2.5 amps) from a source, such as a key switch, that provides power only when the boat is in operation. Consider this additional 2.5 amps of power and how it may affect the reliability of the source. This new circuit should be protected with a 5-amp fuse or circuit breaker per ABYC standards, and it should in no way affect the integrity of the engine’s starting or running operation.

1. Replace any existing engine starting push button or rocker switch with the KBI supplied DPST.
2. Wire the DPST as shown in figures B1, B2, and B3.
3. The Double Pole Single Throw (DPST) switch used in the starting circuit (each engine’s starting circuit) fulfills the requirement to keep each engine starting independent and isolated to just that one engine. One side (circuit) of that DPST switch simply provides the same function as the existing push button or rocker start switch on the vessel. There is no change to functionality. The other side (circuit) of the DPST switch turns on the capacitor providing power to the engine’s (vessel’s) electrical circuit regardless of lead-acid battery condition. The capacitor, the MKSM circuit, does not actually engage the starter motor. The original OEM circuit does that, just as it normally would. All the MKSM is doing is making sure there is power available. After the engines start, the KBI MKSM PLC senses the engine has started (via voltage from Pin 4) and takes over control of the MKSM circuit and recharges the unit. In order to ensure the PLC does not receive a false positive error when the next engine is started, a cube relay inside the MKSM interrupts PLC power supply, causing the PLC to reset. See theory of operation on pages 13 and 14.

The PLC inside the MKSM needs power from a source that provides power only when the engine is running. See Figures B1, B2, and B3.

Figure B1: Multiple Engine Option.....22

Figure B2: Simplified Installation Diagram.....23

Figure B3: Standard DPST Install (MKSMXXX02)24

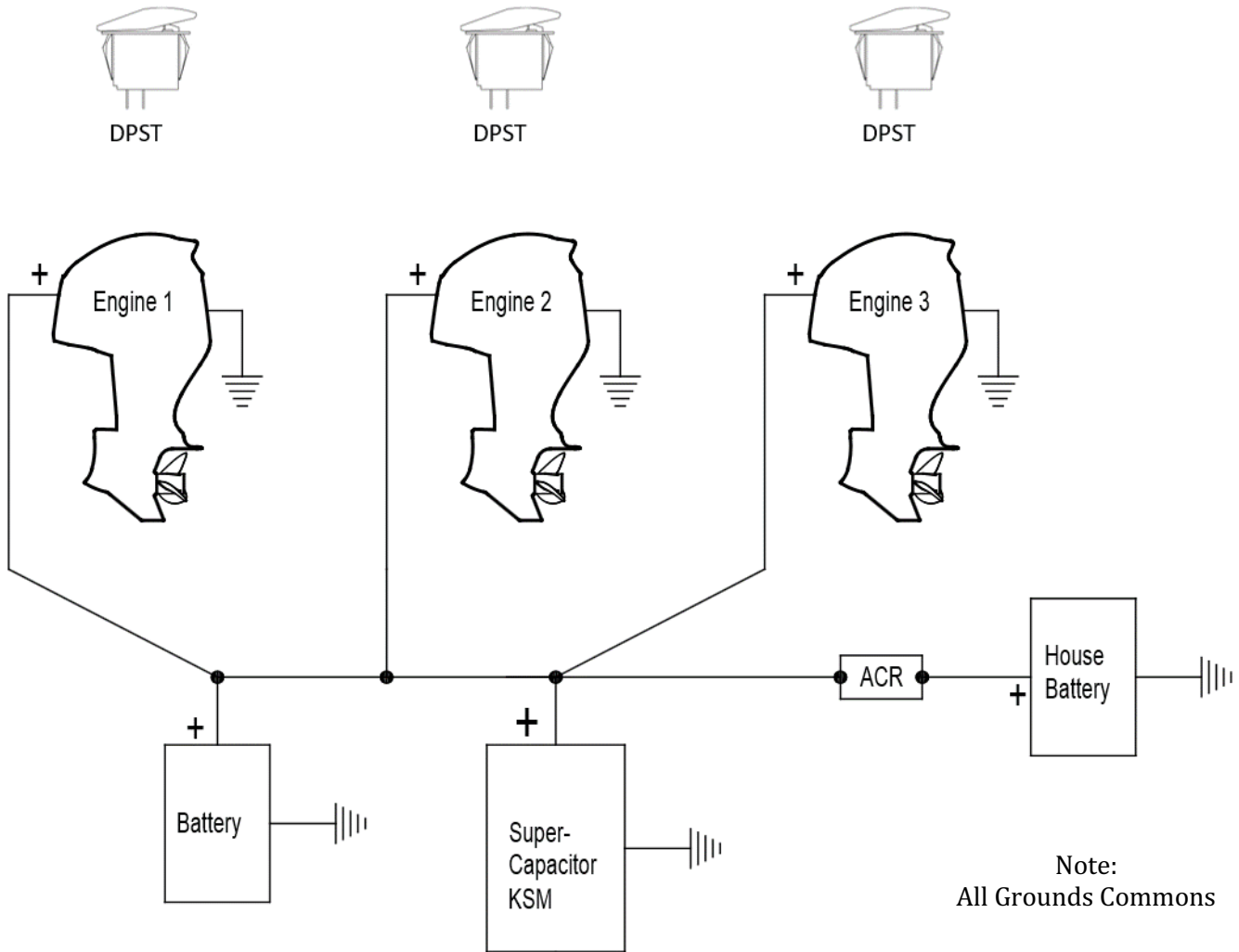

Note:
All Grounds Commons

NOTE: An automatic charge relay (ACR) and house battery are shown for reference only. Not all installations require or use house batteries, but in such a scheme, the house battery could also be used for “emergency” power.

Figure B1: Multiple Engine Option
For use with MKSMXXX02 Models

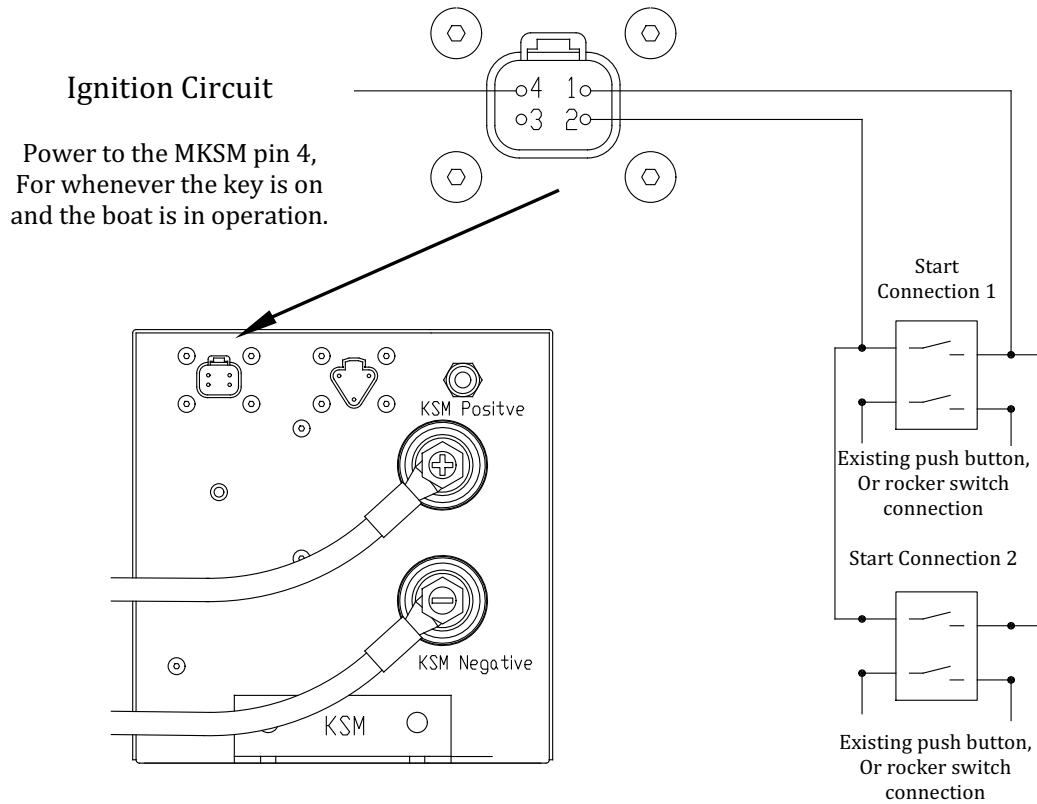

Note: Multiple DPSTs can be used, wired parallel to the MKSM, one for each engine.

Figure B2: Simplified Installation Diagram
For use with MKSMXXX02 Models

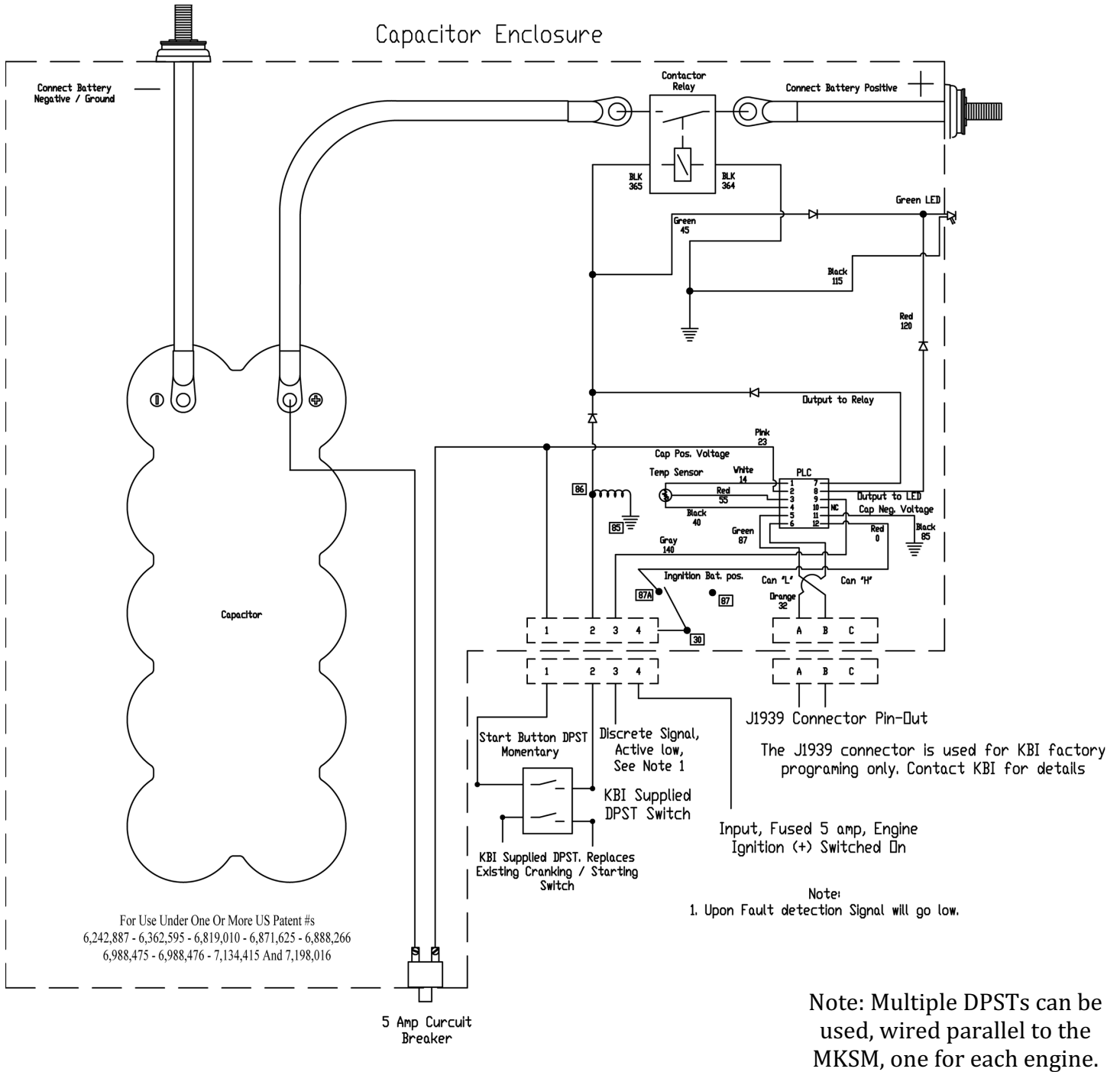

Figure B3: Standard DPST Install
(For use with MKSMXXX02 Models)



Installation Variation #3: For vessels using a keypad, digital switching or key switches for engine starting. Also used for boats with multiple engines not using the DPST installation method.

For use with MKSMXXX01 Models

NOTE: The PLC inside the MKSM needs power (approximately 2.5 amps) from a source, such as a key switch, that provides power only when the boat is in operation. Consider this additional 2.5 amps of power and how it may affect the reliability of the source. This new circuit should be protected with a 5-amp fuse or circuit breaker per ABYC standards, and it should in no way affect the integrity of the engine’s starting or running operation.

When installing MKSM on a boat that incorporates keypad buttons, there are no mechanical switches or buttons to push for engine starting. Using the KBI DPST method of installation, MKSM activation is not an option. Instead you will be using power to activate the MKSM from the engine’s starter motor “S” terminal circuit.

If the OEM engine manufacturer or the boat builder reviews the KBI MKSM Theory of Operation (Pages 13 + 14) and the requirements for DPST-type functionality, then incorporating the DPST-type function and engineering it into the factory build should be no problem. However, when installing a MKSM on a boat that has already been built with keypad button or digital switch starting, the following procedure and hardware (wiring) should be used. See Figures C1, C2, and C3.

NOTE: If battery power was insufficient (<7 volts), too weak to enable an engine start or provide adequate power to the “S” terminal, an emergency start button should be installed (installed near the controls) and would supply capacitor power to enable the entire MKSM system when the button is pushed.

Figure C1: Alternate Method.....26

Figure C2: Power Sources for MKSM Pin 4 and Emergency Start Button.....27

Figure C3: Multiple Engine MKSM Schematic (MKSMXXX01)28

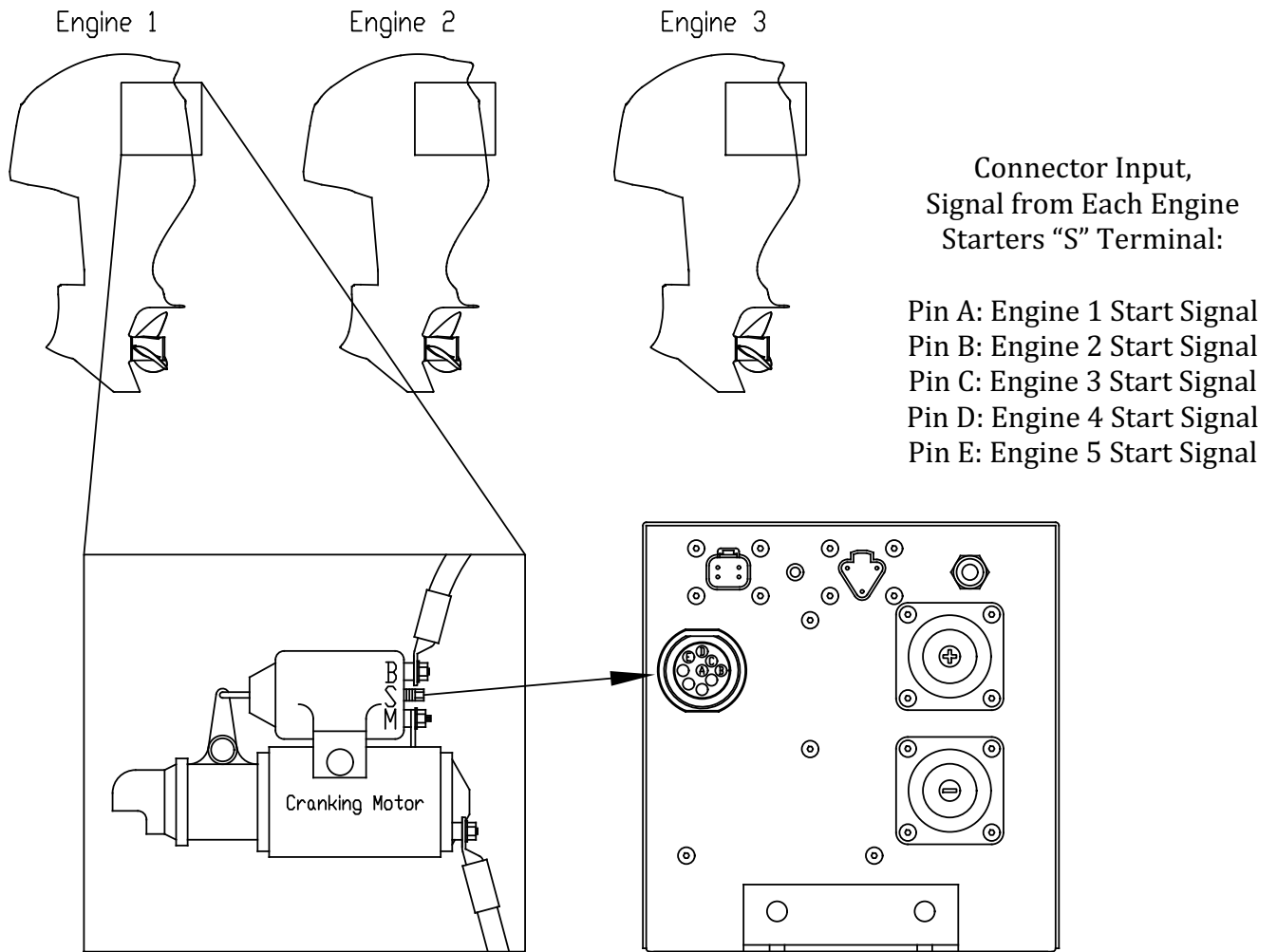
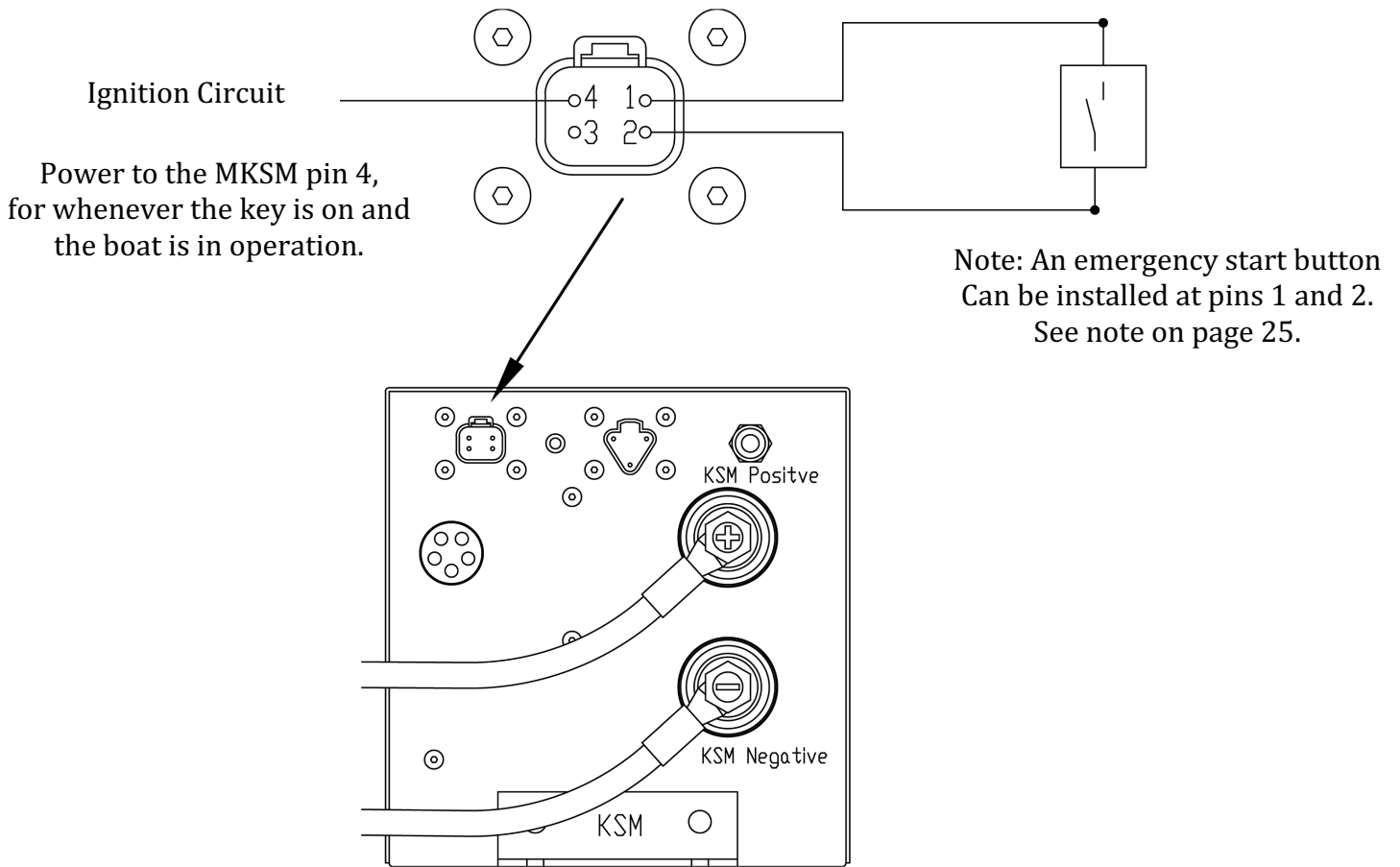

Figure C1: Alternate Method
For use with MKSMXXX01 Models



The PLC inside the MKSM needs power (approximately 2.5 amps) from a source, such as a key switch, that provides power only when the boat is in operation. Consider this additional 2.5 amps of power and how it may influence the source. This new circuit should be protected with a 5-amp fuse or circuit breaker per ABYC standards.



**Figure C2: Power Sources for MKSM Pin 4 and Emergency Start Button
For use with MKSMXXX01 Models**

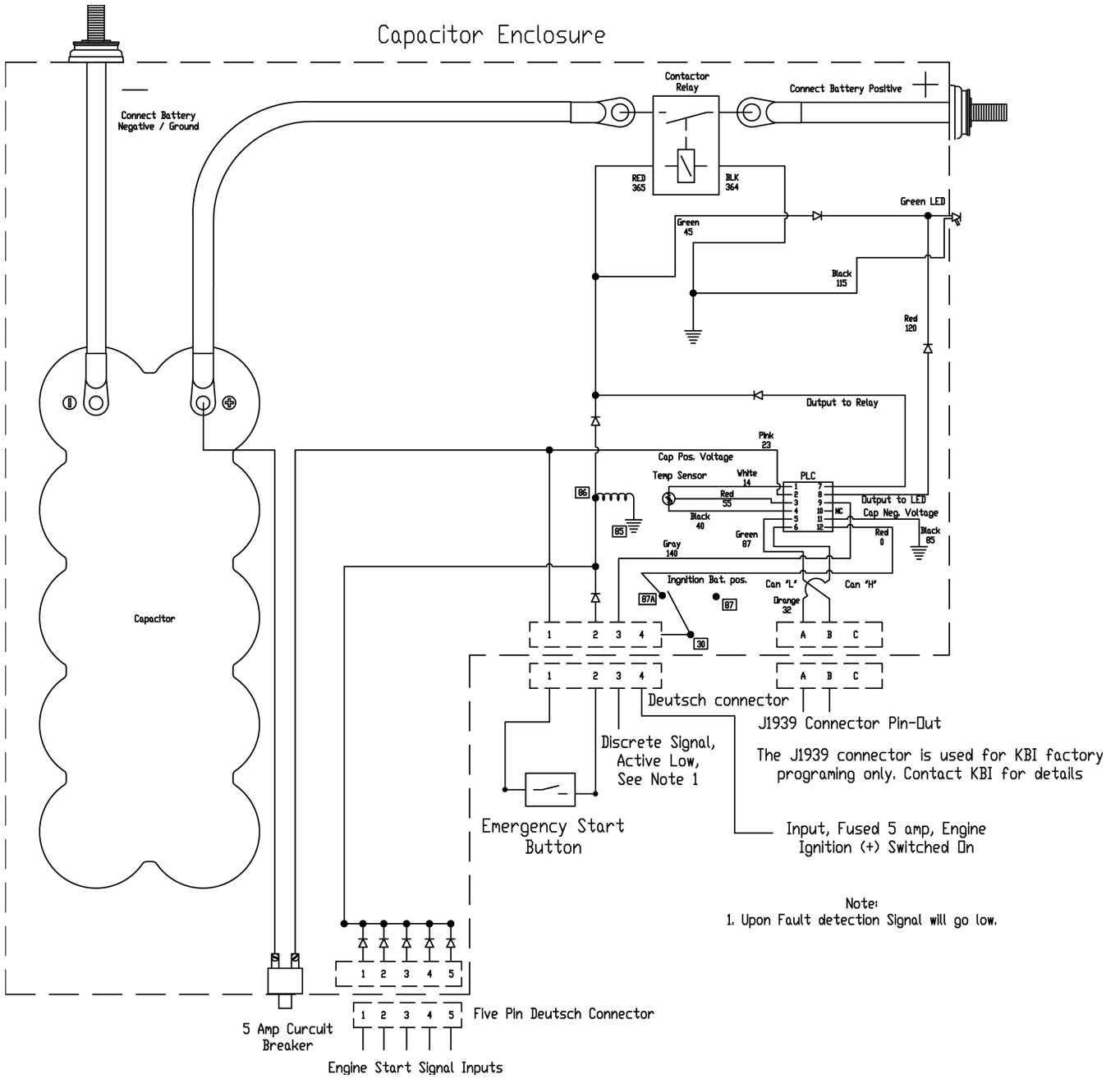

Figure C3: Multiple Engine MKSM Schematic
(For use with MKSMXXX01 Models)



5.0 OPERATION

CAUTION

Do not attempt to bypass the PLC functionality. Charge voltage and temperature shall not exceed the Maximum Voltage and Temperature as specified in Table 1. It is important to MONITOR the voltage when charging the KAPower module to its Maximum Voltage. This is the main purpose and function of the PLC. If the voltage exceeds these ranges, contact KBI for further troubleshooting instructions. Failure to adhere to these specifications will result in premature module failure.

1. Before activation, confirm, using the wiring diagrams on Figure 2 (page 10), and the proper install variation for your application that the MKSM module has been properly installed.
2. Start your vessel, the MKSM will automatically engage if installed properly.
3. By using power from the KAPower capacitor, the MKSM contactor will close and stay closed during engine starting. The previous installation methods are designed to engage the vehicle, vessel, or equipment's OEM cranking motor circuit.
4. Whenever the MKSM KAPower contactor is closed, the LED on the End-Faceplate should be illuminated green.
5. The engine should begin to crank-over with power being supplied from both the MKSM capacitor module and the standard battery(ies).
6. Once the engine starts the MKSM internal PLC module will be active, keeping the contactor closed when required, allowing the KAPower module to recharge.

NOTE: If the vehicle, vessel, or equipment's batteries are completely discharged (if the battery is dead), it may be necessary to keep the DPST switch, or emergency start button pressed until the vehicle's electrical (charging/alternator) system has become active. The dead batteries, on their own, may not support all the engine's electrical power requirements to keep it running. In this case, keep the DPST switch pressed until the vehicle's or vessel's charging system is active. This can be noted by watching the engine's volt or amp meter. The KAPower module will have enough power to keep the engine running until the engine's charging system becomes active.

CAUTION NOTE: *This can only be done if the engine is equipped with automatic starter disengagement. If the starter remains engaged while the start button is pressed, after the engine has started, the starter may be damaged, in which case this procedure cannot be used.*

7. When the engine stops and the vehicle, or equipment is turned off, the MKSM contactor will open, keeping the fully charged KAPower module in reserve for the next engine-starting event.



6.0 TROUBLESHOOTING AND MAINTENANCE

Maintenance of the KAPower module within the MKSM enclosure is not required provided that the operating conditions are proper, and that the requirements specified in this manual are observed.

NOTE: During scheduled maintenance you can disconnect the 4-pin deutsch connector from the MKSM faceplate then start the engine using only the vehicle's or vessel's own key switch or start button. Doing so will prevent the MKSM from coming on-line, thereby allowing the condition of the starting battery to be tested.

1. The LED located on the End-Faceplate of the MKSM indicates the active condition of the MKSM module. See Figure 5 for location of this light. If the LED is not illuminated when expected (see Section 4.3, Theory of Operation), ensure that all wiring and connections are in accordance with the instructions within this manual. Check the integrity of the DPST switch, and the power supply to the PLC (sourced from the engine ignition switched when ON) wiring harness you created.
2. This LED is also an indicator for how the MKSM is functioning. The LED is connected in parallel with the contactor and is also connected to an output on the PLC as shown in the Figure 6. The PLC monitors the capacitor voltage during, and after, the recharge cycle. If the capacitor voltage drops below an acceptable level in the first 5 minutes after the recharge, the LED will flash, indicating a fault. If at any time while the PLC is powered up and the MKSM Circuit Breaker trips or the capacitor voltage level drops below 6-volts (on a 12-volt unit) or 12-volts (on a 24-volt unit), the LED will flash in a sequence that indicates the fault, see Table 2.



Table 2: LED Flash Sequence

Priority	Name	Flash Rate
1	Capacitor Over Temperature	2
5	Temperature Sensor Error	3
4	Contactor Over Current Error	4
2	Low Capacitor Voltage Error	6
3	Rapid Voltage Decay after Recharge	7

6.1 To Check MKSM Internal Circuit

1. If the wiring and harnesses are in good order, continue troubleshooting by unplugging the Deutsch connector on the end-faceplate of the MKSM, providing access to the pin terminals on the MKSM connector. Refer Figure 5, and Figure 6.
2. With the circuit breaker reset, use a voltmeter to check voltage at Pin #1 of the Deutsch four-pin connector and the MKSM negative (-) ground power stud terminal. If voltage is present, the circuit is good. The voltage reading is the actual KAPower module voltage and should be at least 12-volts for the 24-volt models and 6-volts for the 12-volt models in order to activate the contactor.
3. Jump pins 1 and 2 on the four-pin connector, the contactor should activate and make a “clunk” sound. If not, contact KBI for assistance.
4. If experiencing problems check the integrity of the vehicle or vessel side of the wiring harness for issues such as shorts, corrosion, chafing, or bad connections and components.
5. Check the circuit breaker and contactor relay connections within the MKSM module. In order to service or replace any of these components, remove the cover of the MKSM enclosure, with the assistance of KBI.
6. The PLC Module is a sealed unit. It cannot be serviced. If additional troubleshooting is required, contact KBI.



7.0 STORAGE

CAUTION

When not installed the KAPower modules shall be stored within enclosed heated or unheated premises outfitted with a natural ventilation system in regions having moderate or cold weather conditions. Climate control systems are not required. The required storage temperature range is -76° to 158°F (-60° to 70°C).

8.0 TRANSPORTATION

The KAPower MKSM modules can be shipped in approved corrugated cardboard, wooden, or plastic containers. For more information on transportation, contact KBI.



9.0 OPTIONAL VOLTMETER HARNESS

Note: The meter you use may be digital or analog, however it **MUST** be activated only with a momentary on switch or button.

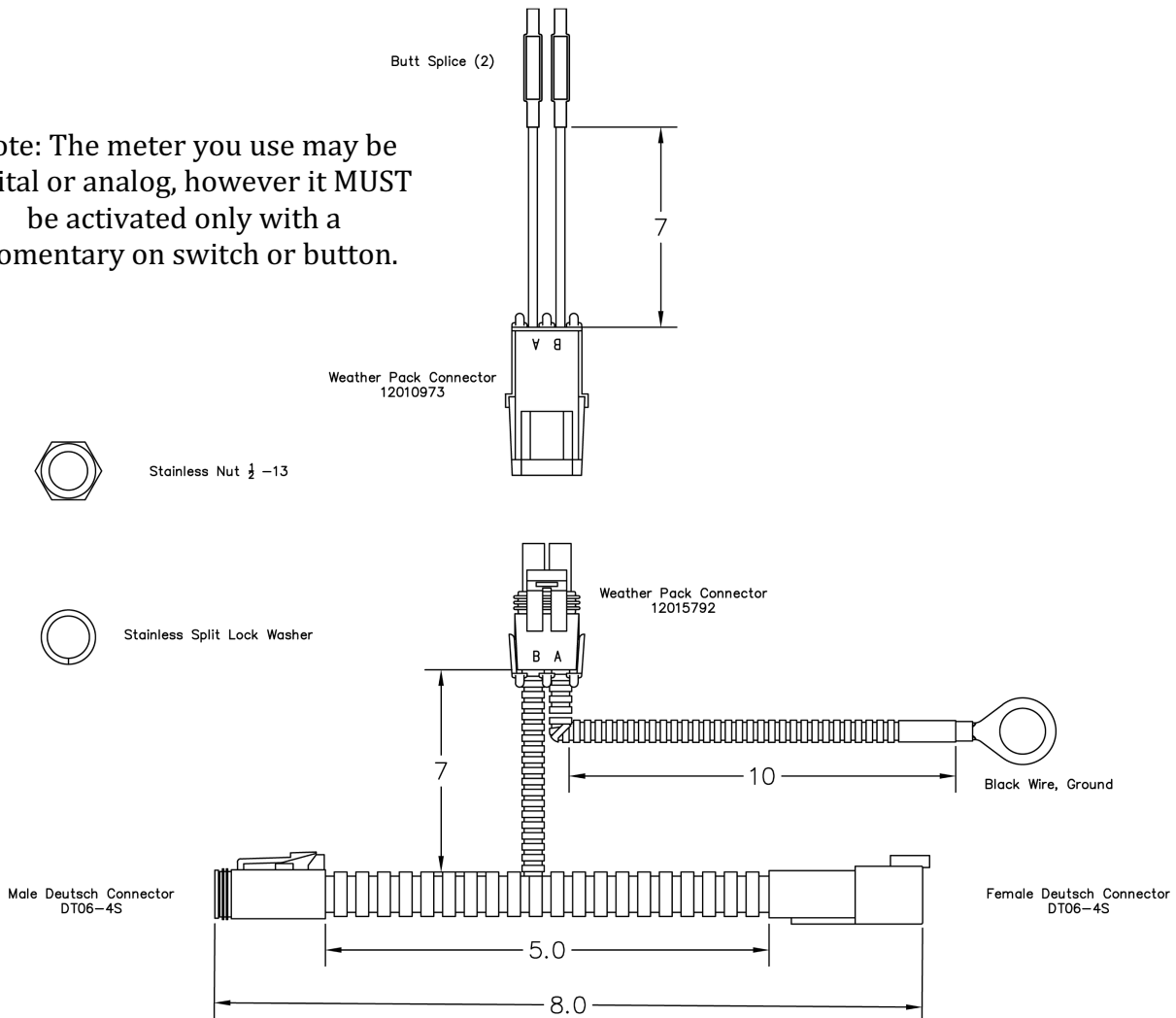

Using this harness with a voltmeter will allow checking of capacitor voltage. The Male end of the harness plugs into the MKSM faceplate. The female end will receive the connector from the vehicle, or vessel. Connect the eyelet over the existing ground connection on the negative post of the MKSM. A voltmeter can then be installed at the butt splices coming from the Weather Pack connector.

Note: Not all KSM models can use external voltmeter, contact KBI for details.



10.0 LIMITED WARRANTY

The KAPower module itself, inside the MKSM, is guaranteed against defects in material and workmanship for three (3) years from date of purchase. All other MKSM components are guaranteed against defects in material and workmanship for one (1) year from the date of purchase. The KAPower module is a sealed unit; do not tamper with this unit. If the MKSM does not operate properly within the warranty period, it must be returned to the factory, prepaid, in order to determine warranty disposition. If factory inspection determines the product to be defective under the terms of this warranty, it will be replaced without charge.

Failure due to accident, abuse, neglect, use other than in the intended application specified in this manual, improper installation or maintenance, mishandling, and repairs or attempted repairs which have been made by others, are not covered under the terms of this warranty.

Kold-Ban International, Ltd. shall not be liable for loss of use of the KAPower MKSM or other incidental or consequential costs, expenses, or damages incurred by the purchaser or user.

This warranty does not include labor for repair or replacement.

**Kold-Ban International, Ltd.
8390 Pingree Road
Lake In The Hills, IL 60156-9637
(847) 658-8561 (800) 527-8278
www.koldban.com**